

SOLDERING IRON - 80W

PRODUCT MANUAL

PART NO. 218123

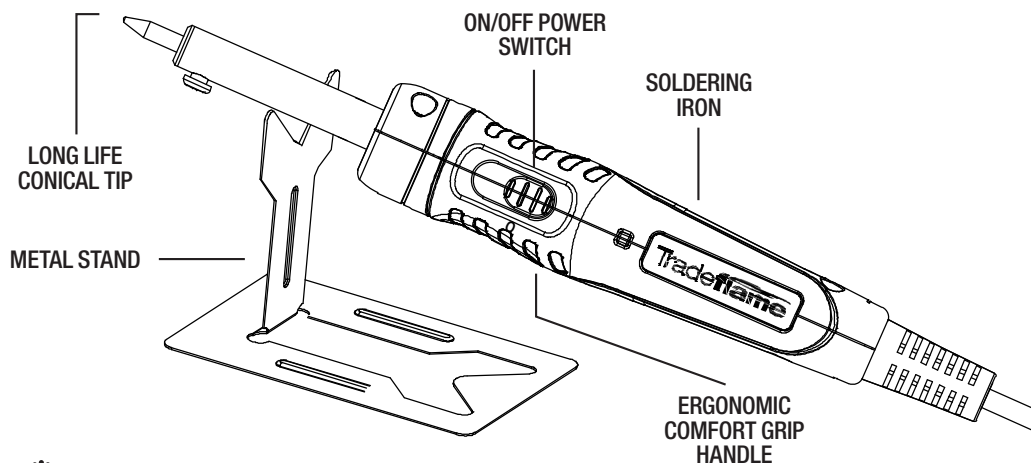

CAUTION: For maximum protection, always wear safety goggles, gloves or other appropriate equipment

SAFETY WARNINGS

Read all safety warnings, instructions, illustrations and specifications provided with this Soldering Iron. Failure to follow all instructions listed below may result in electric shock, and/or serious injury. Save all warnings and instructions for future reference. The term "Soldering Iron" in the warnings refers to your mains-operated (corded) Soldering Irons or battery-operated (cordless) Soldering Irons.

WORK AREA SAFETY

- Keep work area clean and well lit. Cluttered or dark areas invite accidents.
- Do not operate Soldering Iron in vicinity of explosive atmo-liquids, gases or dust. Soldering Irons can create sparks which may ignite the dust or fumes.
- **KEEP CHILDREN AND BYSTANDERS AWAY WHILE OPERATING**

ELECTRICAL SAFETY

- Indoor use. Do not expose Soldering Iron to rain or wet conditions. Water entering a Soldering Iron will increase the risk of electric shock.

PERSONAL SAFETY

- Stay alert, watch what you are doing and use common sense when operating a Soldering Iron. Do not use a Soldering Iron while you are tired/distracted or under the influence. A moment of inattention while operating a Soldering Iron may result in serious personal injury.
- Use personal protective equipment. Always wear eye protection. Protective equipment such as a dust mask, non-skid safety shoes, hard hat or hearing protection used for appropriate conditions will reduce personal injuries.
- **PREVENT UNINTENTIONAL STARTING. ENSURE THE SWITCH IS IN THE OFF POSITION BEFORE CONNECTING TO POWER SOURCE, PICKING UP OR CARRYING THE SOLDERING IRON.**
- Do not overreach. Keep proper footing and balance at all times. This enables better control of the Soldering Iron in unexpected situations.
- Dress properly. Do not wear loose clothing or jewellery. Keep your hair and clothing away from moving parts. Loose clothes, jewellery or long hair can be caught in moving parts.
- Do not let familiarity gained from frequent use of the Soldering Irons allow you to become complacent and ignore Soldering Iron safety principles. A careless action can cause severe injury within a fraction of a second.

SOLDERING USE AND CARE

- Do not force the Soldering Iron. Use the correct Soldering Iron for your application. The correct Soldering Iron will do the job better and safer at the rate for which it was designed.
- Do not use the Soldering Iron if the switch does not turn it on and off. Any Soldering Iron that cannot be controlled with the switch is dangerous and must be replaced.
- Disconnect the plug from the power source and/or turn off the battery, from the Soldering Iron before making any adjustments, changing accessories, or storing Soldering Iron. Such preventive safety measures reduce the risk of starting the Soldering Iron accidentally.

NOTE For illustration purposes only. Contents for each soldering iron might vary please check packaging for exact description.

- Store idle Soldering Iron **OUT OF THE REACH OF CHILDREN** and do not allow persons unfamiliar with the Soldering Iron or these instructions to operate the Soldering Iron. Soldering Iron are dangerous in the hands of untrained users.
- Maintain Soldering Iron and accessories. Check for misalignment or binding of moving parts, breakage of parts and any other condition that may affect the Soldering Iron's operation. If damaged, have the Soldering Iron repaired before use. Many accidents are caused by poorly maintained Soldering Iron.
- Use the Soldering Iron, accessories and Soldering Iron bits etc. in accordance with these instructions, taking into account the working conditions and the work to be performed. Use of the Soldering Iron for operations different from those intended could result in a hazardous situation.
- Keep handles and grasping surfaces dry, clean and free from oil and grease. Slippery handles and grasping surfaces do not allow for safe handling and control of the Soldering Iron in unexpected situations.
- Do not expose a Soldering Iron to fire or excessive temperature. Exposure to fire or temperature above 130°C (265°F) may cause explosion.

SPECIFIC SAFETY RULES FOR SOLDERING IRONS

- Contact with a hot tip could ignite flammable materials. Contact with a hot tip could ignite a fire.
- While in use do not stand or store Soldering Iron on its side. Soldering Iron could tip resulting in contact between hot tip and flammable materials. Always set/store Soldering Iron on metal stand provided.
- Do not place Soldering Iron in coil stand.
- Keep hands clear of the tip serious burns can occur if skin contacts tip.
- Work in well ventilated areas. Soldering can produce fumes and smoke.
- Use personal protective equipment when using
- This Soldering Iron is not intended for use by persons (including children) with reduced physical, sensory or mental capabilities, or lack of experience and knowledge, unless they have been given supervision or instruction concerning use of the appliance by a person responsible for their safety.
- **KEEP AWAY FROM CHILDREN**
- To reduce the risk of fire, personal injury, and product damage due to a short circuit, never immerse your Soldering Iron, battery pack or charger in fluid or allow a fluid to flow inside them. Corrosive or conductive fluids, such as seawater, certain industrial chemicals, and bleach or bleach-containing products, etc. can cause a short circuit.
- To reduce the risk of injury, always wear safety goggles or glasses with side shields. Keep hands and fingers behind finger guard. Serious burns could occur if skin contacts a hot tip.

ACCESSORIES

Use only recommended accessories. Others may be hazardous.

For a complete listing of accessories, go online to www.tradeflame.com

Tradeflame®

SOLDERING IRON - 80W PRODUCT MANUAL

PART NO. 218123

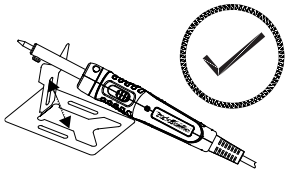

Correct storage of Soldering Iron when not in use.

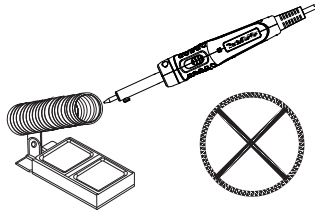

Do not place in coil holder.



WARNING Hot tip when in use, do not touch, keep Soldering Iron clean and away from oils and lubricants. Do not immerse Soldering Iron in water.



Do not modify or attempt to repair the Soldering Iron except as indicated in the instructions for use and care.

CHANGING THE SOLDERING TIP

Ensure the tip is cool and Soldering Iron is switched off and unplugged from mains current before touching the tip as serious burns could occur to skin if touched.

1. Unscrew the nut enough to release the tip from the barrel.

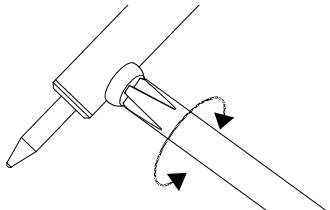

2. Remove the tip and replace.

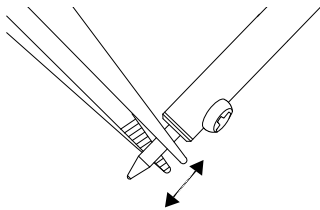

3. Tighten the nut securely, ensuring you do not over tighten and cause any damage.

SOLDERING HINTS

- Re-tin the tip (cover the heated tip with solder) prior to use.
- Use the Soldering Iron to heat the work items and apply solder directly to the work items – not to the Soldering Iron tip.
- Clean the tip with the **Tradeflame Brass Tip Cleaner (Part number 218167)** or a damp sponge after use – do not file tip.
- Use the metal stand when Soldering Iron is not in use

OPERATING

1. Prepare the work area and piece
2. Ensure the Soldering Iron tip and work items are clean.
3. Make sure Soldering Iron tip is fixed in position and secure.
4. Connect Soldering Iron to mains current and place on the metal stand provided.
5. To turn on push the power switch forward.
6. Surfaces of the connection points must be clean.
7. "Tin" the tip by covering the heated tip with **Tradeflame Solder**.
8. Use the Soldering Iron to heat the connection points, not the solder.
9. Apply only enough solder to the heated parts.
10. Allow the joint to cool undisturbed.
11. To turn off the Soldering Iron, pressing switch back.
12. While still hot, clean the tip with the **Tradeflame Brass Tip Cleaner (Part number 218167)** or a lightly damp sponge. **WARNING Avoid contact, tip is hot and could cause serious burns.**
13. Place Soldering Iron on Metal Stand provided on its side with the tip away from working area.
14. Turn the mains current off and unplug the Soldering Iron.
15. Let the Soldering Iron to cool down naturally
16. Once tip has cooled store in a safe and dry space.