

Tradeflame®

HANDYMAN SOLDERING TORCH KIT PRODUCT MANUAL

PART NO. 411267

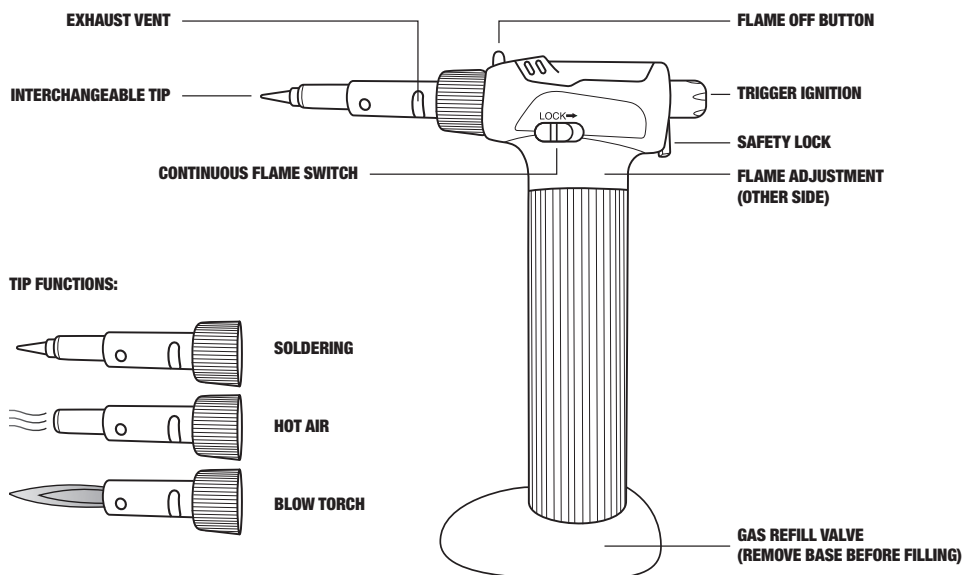

CAUTION: For maximum protection, always wear safety goggles, gloves or other appropriate equipment



WARNING

- Contents of unit when filled are extremely flammable and under pressure.
- Keep out of reach of children or anyone who has not read the instructions.
- Use this Soldering Torch with Butane fuel only. Use of non-recommended fuel will void your warranty.
- Carefully read cautions on your fuel cartridge.
- Keep away from heat and flame. DO NOT store at temperatures above 49°C (120°F).
- DO NOT store in rooms used for habitation.
- Always point away from face, body, and clothing when igniting or using.
- Keep hands and face away from the torch when it is in use. There are times when the flame is difficult to see, so work with caution.
- Avoid overheating the torch, allow for short rest periods between uninterrupted uses.
- Never leave the torch in direct sunlight or in areas where a stove or heater generates a high temperature of 40°C (104°F).
- Never puncture torch or place torch near an open flame of any type including but not limited to fire places or pilot flames.
- Do not touch the tip of the torch after usage. The tip will become extremely hot to touch.
- Never disassemble the torch or modify it in any way by adding to or removing parts. Any such activity may be hazardous and result in property damage or bodily harm.
- Once filled **DO NOT PUT IN LUGGAGE OR TAKE ON ANY TRAIN OR AIRCRAFT.**

OPERATING INSTRUCTIONS

GAS REFILLING

- Prior to refilling with butane, remove the base of the torch. Make sure that the gas refill valve has not been damaged and is secure in the bottom of the torch.
- **USE ONLY BUTANE FUEL.** Use with Tradeflame Butane Gas Refill 70g (10000602 / 326602) & 200g (10000603 / 326603)
- Shake the butane fuel cartridge lightly a few times to warm up the fuel within the cartridge.
- Move the flame adjustment dial to the “-” position.
- Turn the torch upside down orientating the gas refill valve pointing up.
- Mate the butane nozzle vertically with the gas refill valve and apply light pressure to the butane cartridge nozzle to the gas refill valve. A light pumping action works best to properly fill the torch. **CAUTION** – Fill fuel tank on the torch to approximately 80% capacity. Do not overfill! Too much pressure will result in fuel back spray, which is flammable. If the butane cartridge nozzle and gas refill valve are not aligned it may result in fuel back spray as well.
- After refilling, allow a few minutes for the gas to stabilize before operating.

IGNITING THE TORCH

- Move the flame adjustment dial to the “+” position. Small adjustments may be required dependent on your altitude and the temperature. Extreme cold temperatures create an environment where the torch is difficult to light. This is normal.
 - Release the safety lock by sliding the lock down towards the bottom of the torch. You should feel a small click indicating the lock has been released.
 - Hold the torch in your hand and point the nozzle away from yourself, anyone near you, or any flammable liquids or objects. Use your thumb to depress the trigger ignition inwards. It is not uncommon for you to have to press the trigger ignition two or three times to ignite the torch.
- Note:** Each try will require sliding down the safety lock before pressing the trigger ignition.

COLD WEATHER OPERATION

- In colder weather the size of the flame will be smaller. To produce a larger flame, pre-warm the Soldering Torch to room temperature prior to use. To warm the fuel up, shake the torch a few times. There is a greater possibility that the flame will extinguish when the torch is turned upside down in cold weather.

USING CONTINUOUS FLAME FEATURE

- For a continuous flame, move the continuous lock to the right, towards the trigger ignition.

FLAME ADJUSTMENT

- Moving the flame adjustment dial towards the “+” will increase the flame size. Moving the flame adjustment dial towards the “-” will decrease the flame size. For best results, keep the flame length at about 10 – 25 mm (1/2” – 1”). Do not make flame too long as it will only waste fuel and make the flame unstable.
- There are many factors that impact the flame setting and the ability of your torch to burn. There are times due to temperature or altitude that your torch may not react to the settings of the flame adjustment dial as in normal conditions. Adjust the dial to create the desired flame.

TURNING OFF THE TORCH

- Releasing the trigger ignition will extinguish the flame if the torch does not have the continuous lock on.
- In order to extinguish the flame when the continuous lock is on, slide the continuous lock to the left, towards the front of the torch.
- For quick extinguishment of flame, press the fuel cut off button on top of the torch. **This will temporarily stop the fuel but WILL NOT turn the torch off.** You will still need to turn off the torch by the above steps.
- Residual gas may keep the flame burning briefly. Make sure the flame is completely extinguished before setting torch down or storing torch.

DANGER:

**ALWAYS USE YOUR HANDYMAN SOLDERING TORCH
IN A WELL VENTILATED AREA**

**ONCE FILLED WITH BUTANE, CONTENTS EXTREMELY FLAMMABLE AND
UNDER PRESSURE. KEEP OUT OF REACH OF CHILDREN.**

Tradeflame.com

tradeflame tradeflameTOOLS